

Simag SPR80 - 70kg production 25kg storage

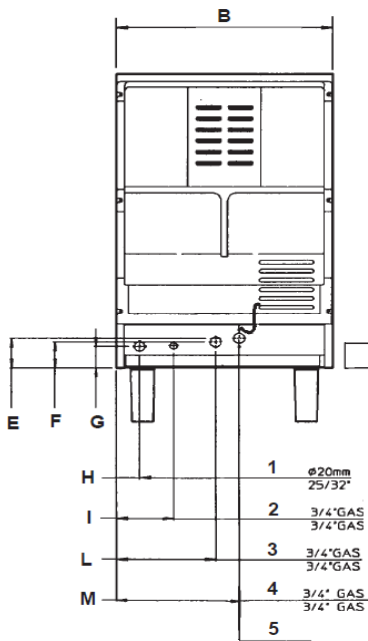

One-year manufacturer warranty

SPECIFICATION



DIMENSIONS

Width 529 mm
 Depth 626 mm
 Height 797 / 927 mm with legs

PLUMBING CONNECTIONS

(5) 10 amp 1 metre power lead 80 mm
 (G) 20mm Water Outlet Gravity 58 mm
 (F) 3/4" Water Inlet 70 mm